

# EAST-ADL Introduction

Relation to AUTOSAR



# General

- EAST-ADL:

to support the engineering effort for automotive embedded systems



- AUTOSAR

to capture the software architecture\*

\*Architecture in the sense of components and their relationships to one another

# 2 Kinds of Differences

- Abstraction Levels:  
EAST-ADL complements AUTOSAR with higher levels of abstractions
  - Vehicle Level
  - Analysis Level
  - Design Level
- Engineering Information Scope:  
EAST-ADL complements AUTOSAR with more concepts
  - Requirements Engineering
  - Variant Management
  - Timing
  - Safety
  - Behaviour (nominal/error)

Scope in  
AUTOSAR

depending  
on version

# Important Similarity

- Same “Meta-Meta Model”

AUTOSAR Meta Modelling Guideline used  
= Easy to integrate AUTOSAR and EAST-ADL

- Domain Model of EAST-ADL  
(Meta Model)

- Defined in Enterprise Architect
- AUTOSAR template profile (atp stereotypes) applied
- Possible to process through AUTOSAR MMT tool

# The Abstraction Level Difference

## EAST-ADL Defines

- (on Design level)
  - Hardware entities/topology
  - Functional structure & behavior
  - Function-to-ECU allocation
- These engineering decisions are constraints for AUTOSAR SW Architecture and mapping

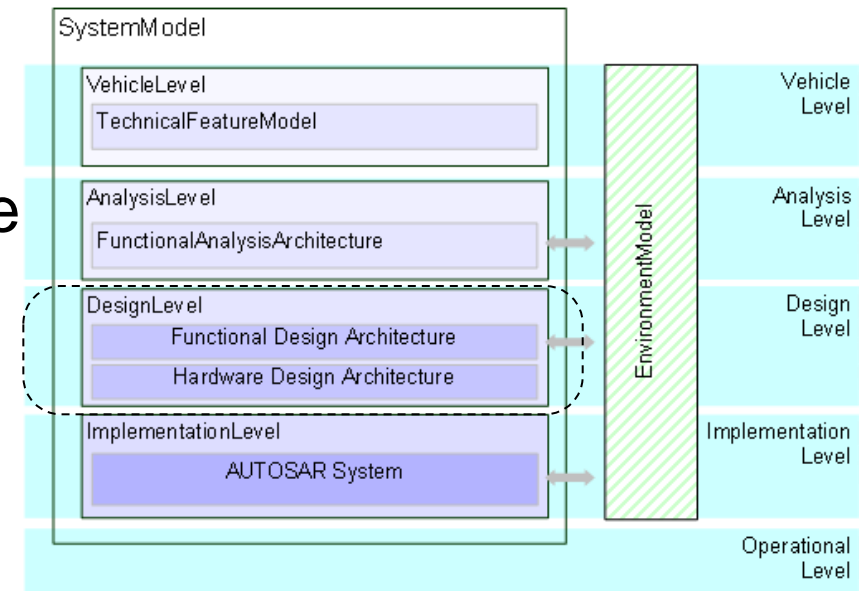

# The Abstraction Level Difference

## AUTOSAR defines

- Hardware entities and topology with enough detail to support software configuration
- Software components with runnables
- Mapping to tasks and frames
- Mapping to ECUs and busses

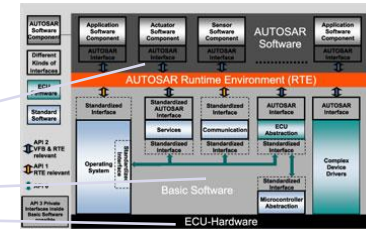
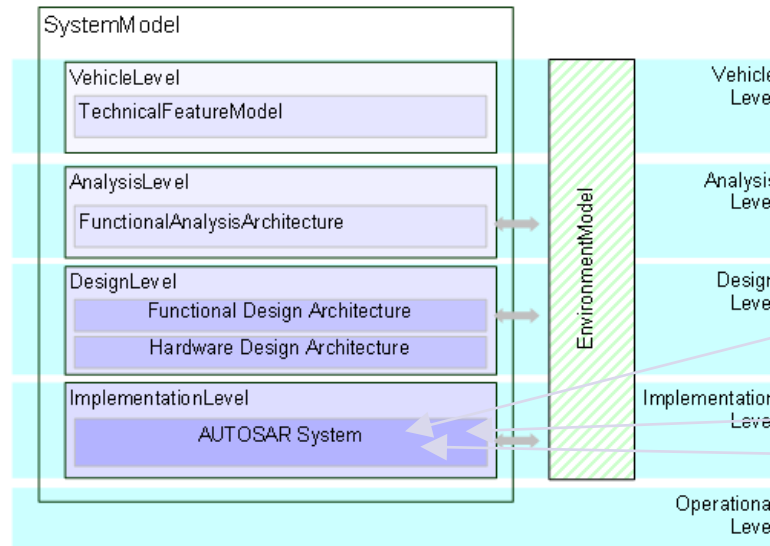

# Software versus Functional Architecture

- Software architecture and functional architecture are orthogonal
- Software architecture
  - A system decomposition from an implementation viewpoint corresponding to the final product
- Functional architecture
  - A system decomposition from an functional viewpoint defining the logical parts of the system and how they interact

The same functional architecture may be “packaged” in several ways resulting in different software architectures

*EAST-ADL concepts capture information that is the rationale for an implementation description using AUTOSAR concepts*

# Structural Compliance

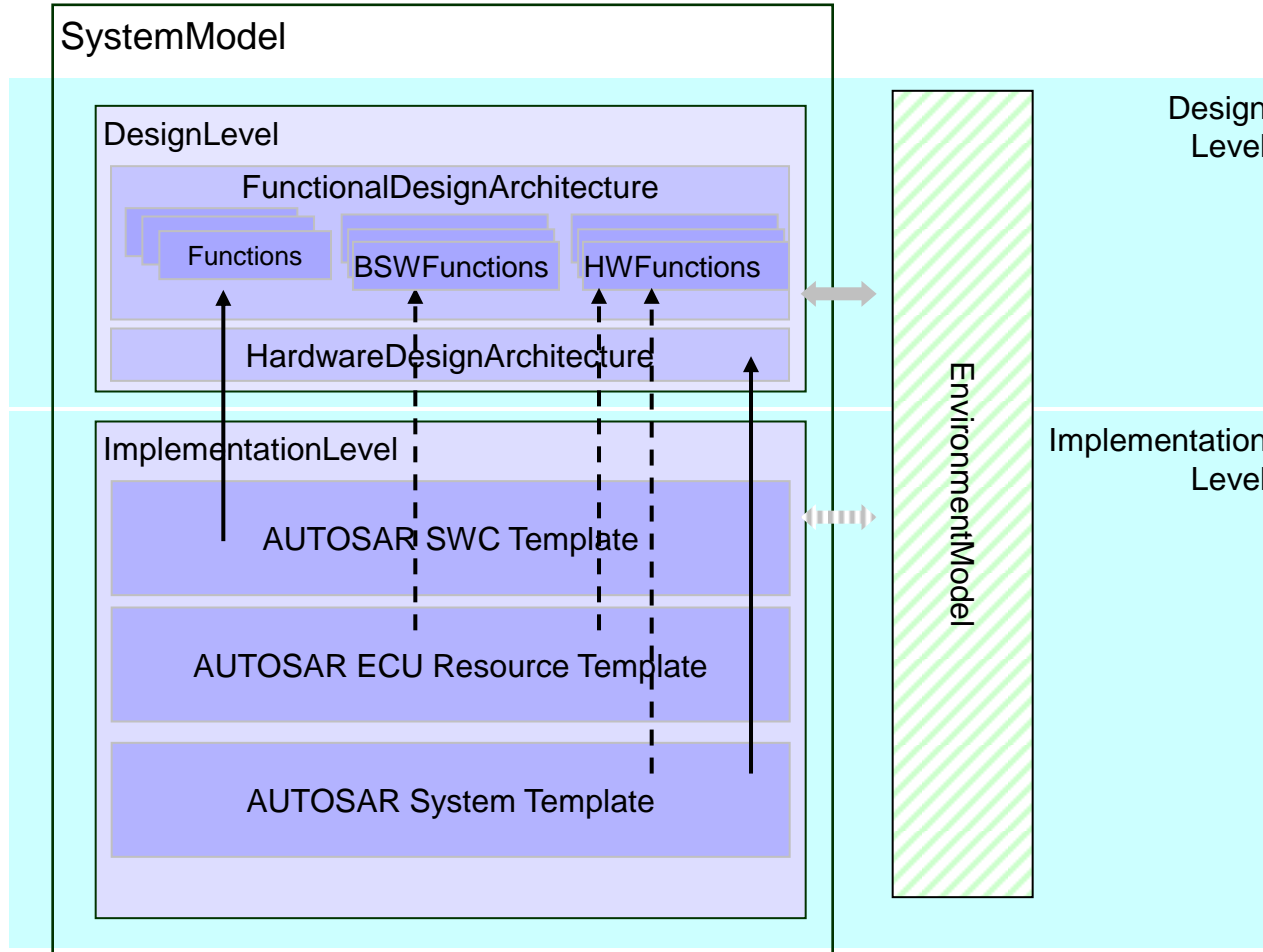

# Mapping of EAST-ADL to AUTOSAR

- Runnable is the behavioural entity in AUTOSAR (Software Component is structure)
  - Function represents structure and behavior in EAST-ADL
  - => Fundamental mapping is 'Function – Runnable'
  - Different mappings are possible
    - 'Function – AR Composition'
    - 'Function – AR Software Component'
- ('1 Function – n Composition/Software Component/Runnable' is "incorrect")

# A possible methodology

1. Define functional structure in EAST-ADL
  2. Optional: Identify blocks that should go together in a Software Component and put constraints regarding components
  3. Define AR Software Components and Runnables
  4. Map elementary or composite Functions to appropriate AR Software Components or Runnable (Realization relation)
- the behavior of the runnable is defined in the corresponding Function
  - the packaging into SWC/runnables is independent of functional structure
  - SW architecture can be traced back to functions, features, requirements

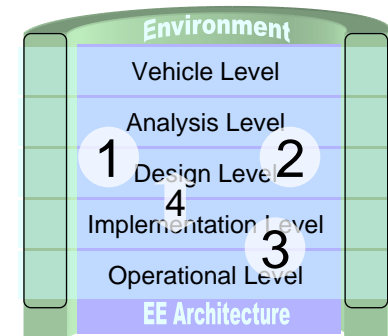

# Examples of function-to-component Mappings

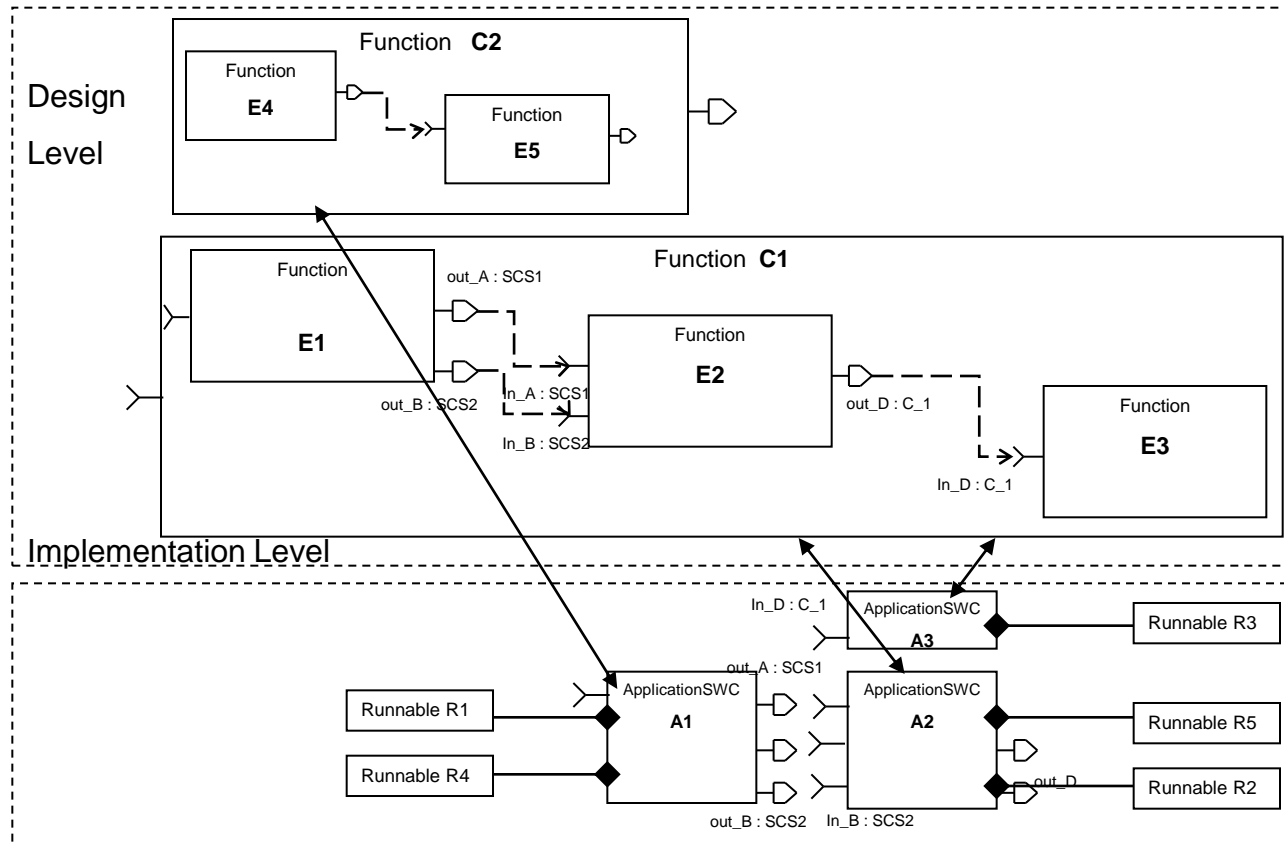

(Composite) Function to SW Component

# Examples of function-to-component Mappings

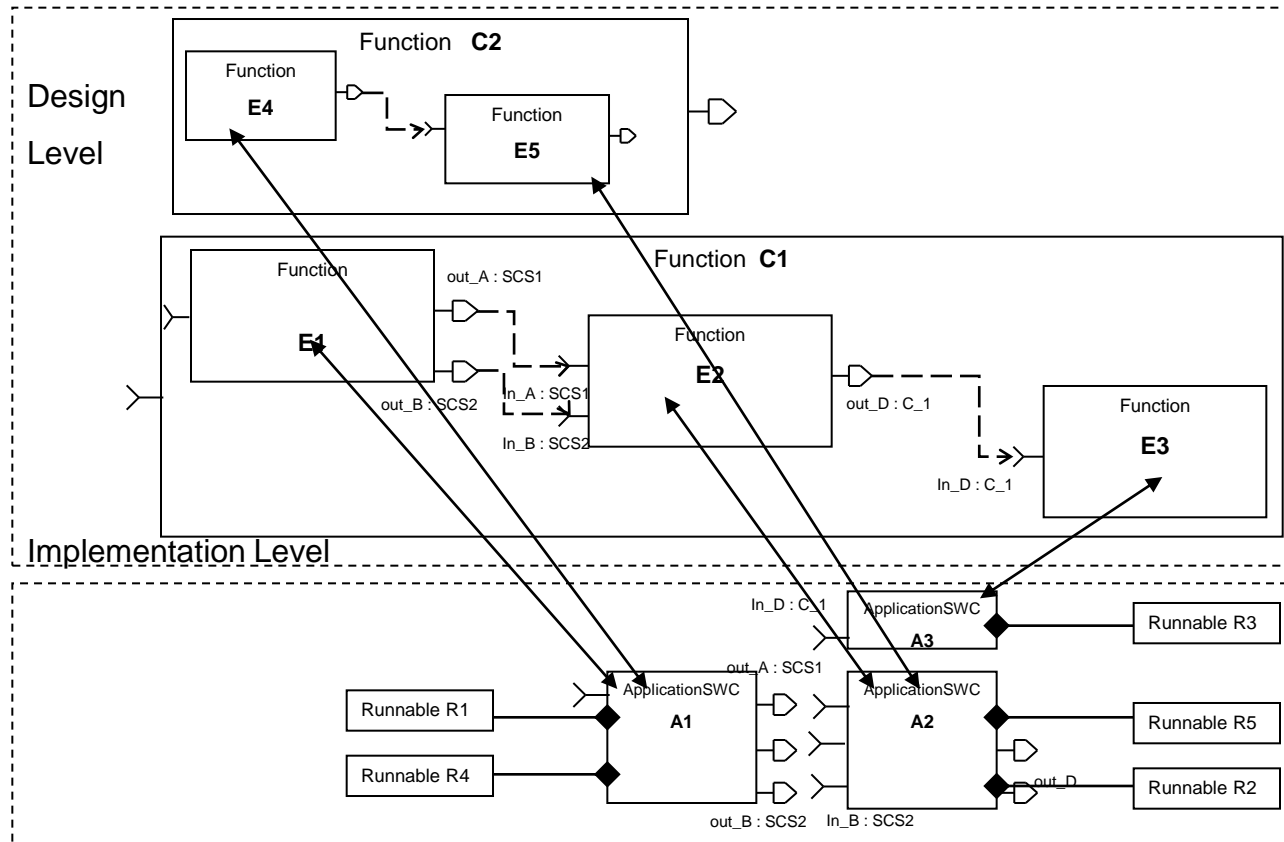

n Function to 1 SW Component

# Examples of function-to-component Mappings

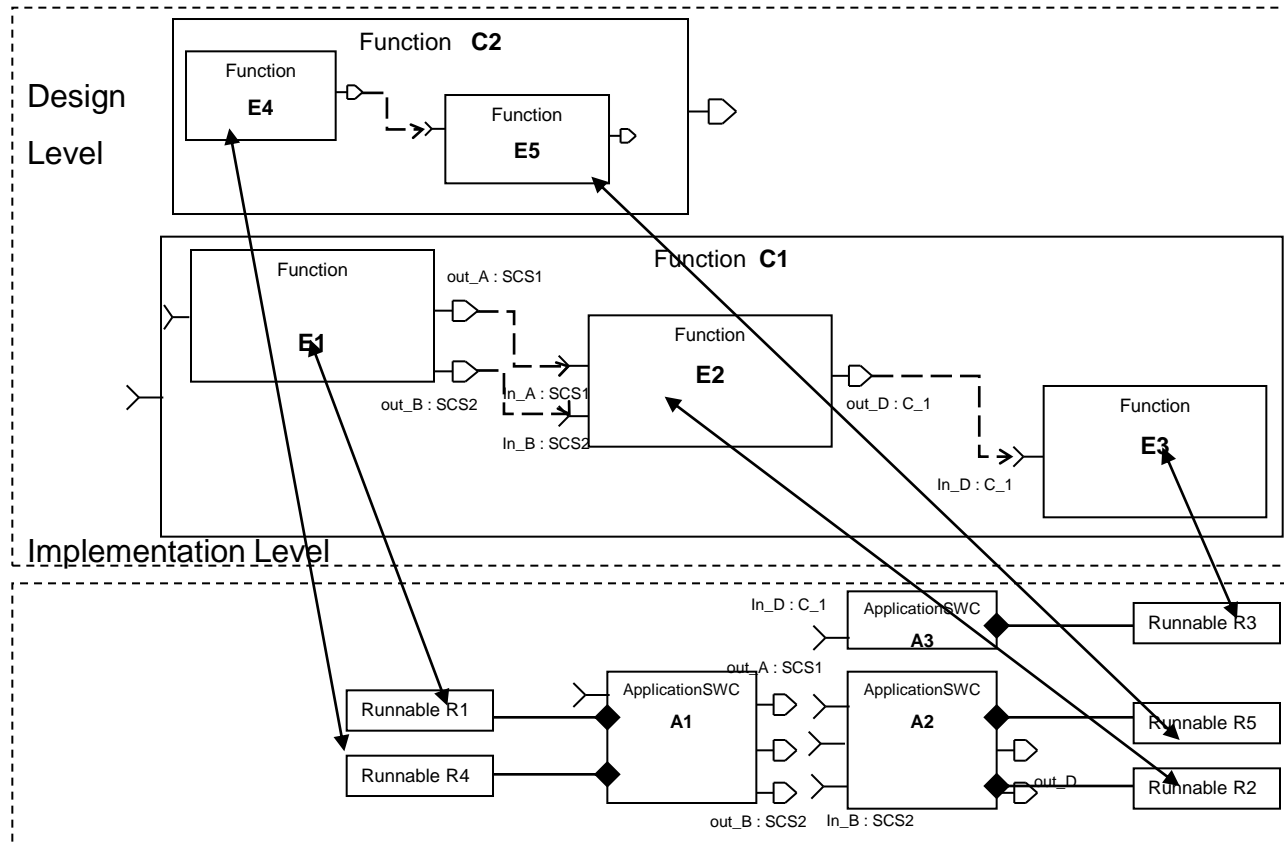

## Function to runnable

# The Information Scope Difference

## A Modular View of EAST-ADL

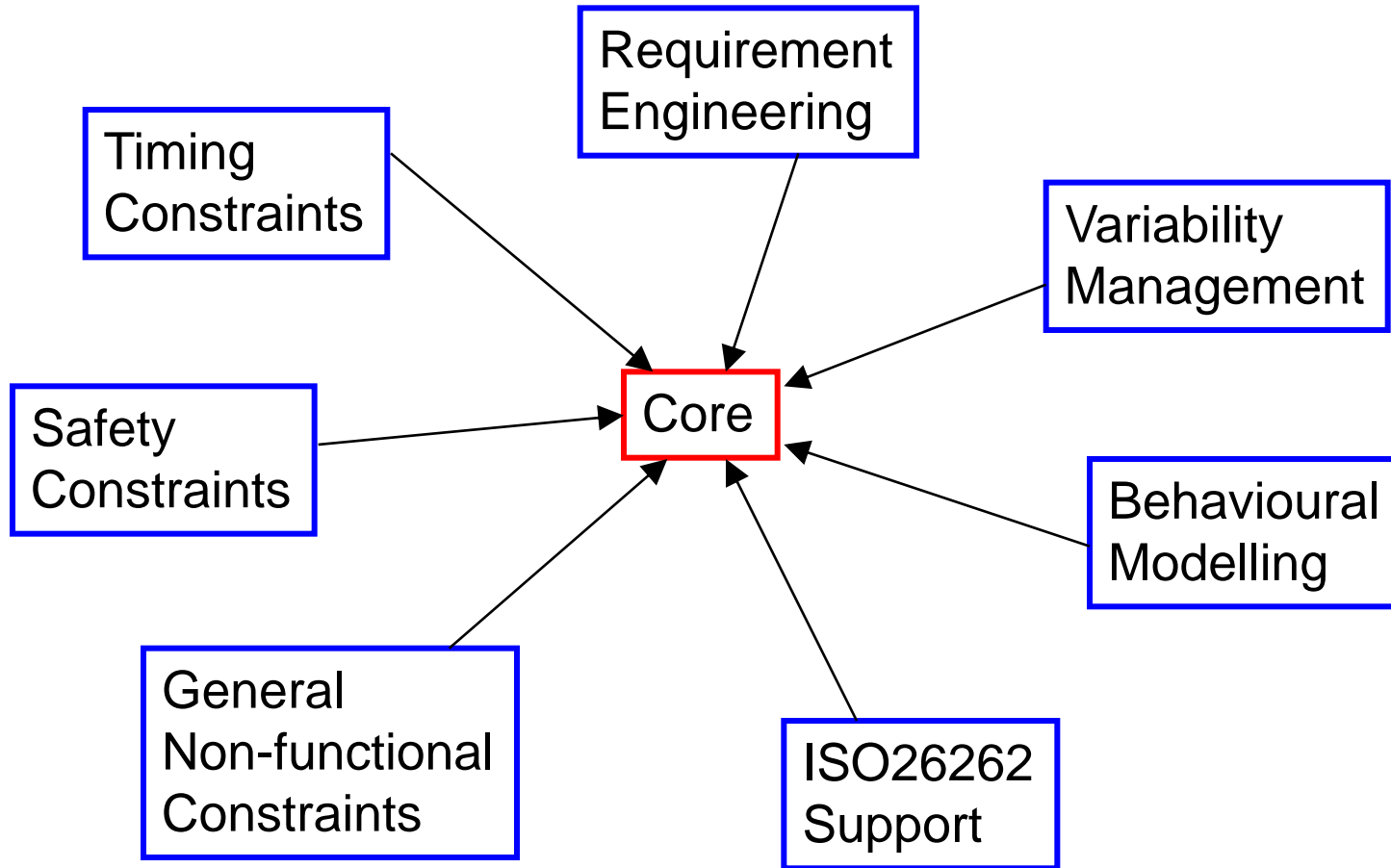

# The Information Scope Difference

Adding Capability to EAST-ADL  $\Rightarrow$  Adding also to AUTOSAR

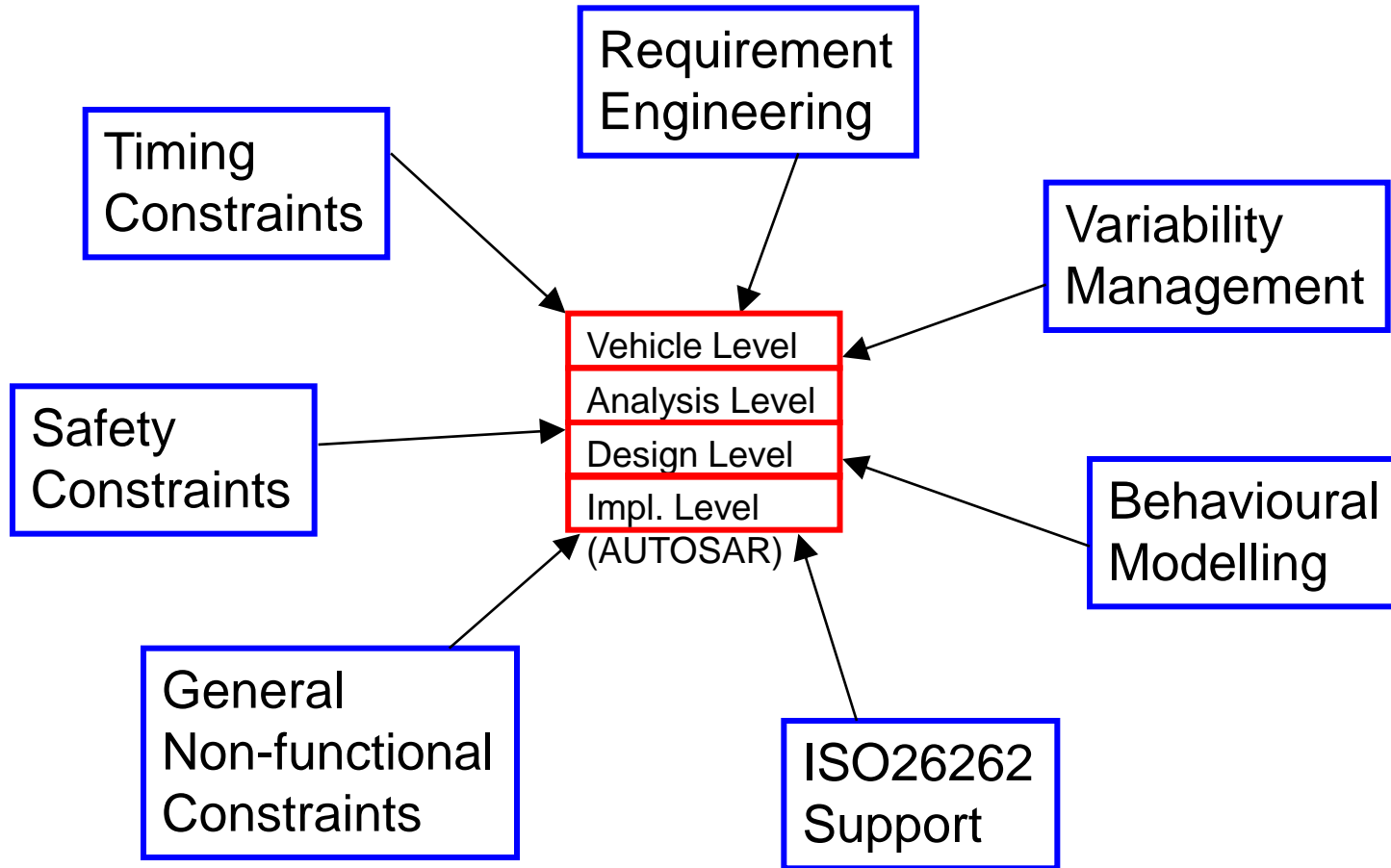

# Conclusions

- Abstraction Levels / Separation of Concerns
  - AUTOSAR
    - Defines the software architecture
    - Implementation details
  - EAST-ADL
    - Design Level defines the functional architecture
    - Logic/Functional aspects
  
- Concepts / Information Scope
  - AUTOSAR
    - Limited scope
    - Higher in later versions
  - EAST-ADL
    - Broader scope
    - Capable to Enrich AUTOSAR on Implementation Level